

445FB STATIONARY LOUVER ROLL FORMED STEEL

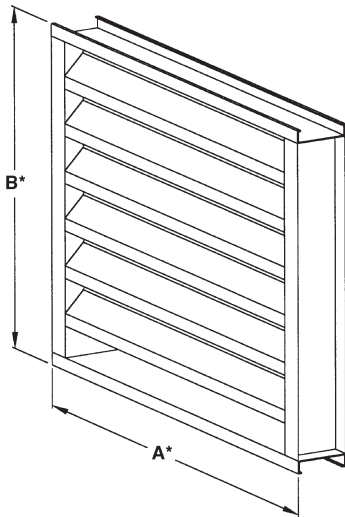

STANDARD CONSTRUCTION

FRAME 16 ga
4" (102) deep, ~~18~~ gage (1.3) galvanized steel.

BLADES 18 ga
~~20~~ gage (1.0) galvanized steel, J-style blades (formerly "weatherproof") are positioned at 45° angle and spaced approximately 5" (127) center to center.

SCREEN
1/2" x 19 gage (13 x 1.1) galvanized bird screen in removable frame. Screen adds approximately 1/2" (13) to louver depth.

FINISH
Mill.

MINIMUM SIZE
12"w x 12"h (305 x 305).

APPROXIMATE SHIPPING WEIGHT
6 lbs. per sq. ft. (29.3 per m²).

MAXIMUM FACTORY ASSEMBLY SIZE
64 sq. ft. (6m²) per section, not to exceed 120"w x 90"h (3048 x 2286) or 90"w x 120"h (2286 x 3048).
Louvers larger than the maximum factory assembly size will require field assembly of smaller sections.

SUPPORTS
Louvers may be provided with rear mounted blade supports that increase overall louver depth depending on louver size, assembly configuration or windload.

Consult Reliable for additional information.

FEATURES

- The 445FB:
- 45% Free Area.
 - Published performance ratings based on testing in accordance with AMCA Publication 511.
 - Hidden mullions for attractive appearance.
 - Economical galvanized steel construction.

VARIATIONS

Variations to the basic design of this louver are available at additional cost. They include:

- Extended sill.
- Hinged frame.
- Front or rear security bars.
- Filter racks.
- Installation angles.
- A variety of bird and insect screens.
- Selection of finishes: prime coat, baked enamel (modified fluoropolymer), epoxy, Acrodize and Kynar.

Consult Reliable for other special requirements.

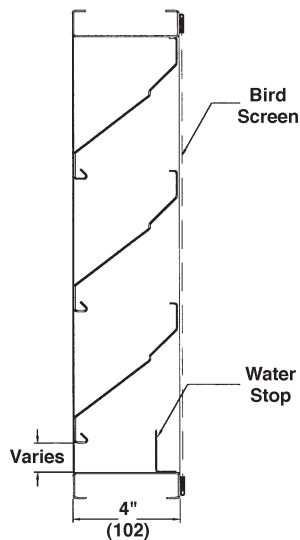

FRAME CONSTRUCTION

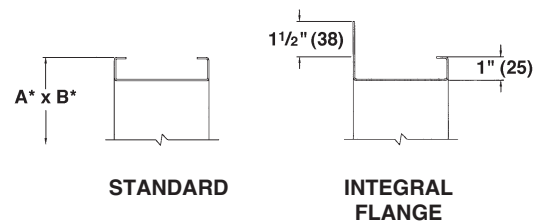

Dimensions in inches, parenthesis () indicate millimeters.

*Units furnished 1/4" (6) smaller than given opening dimensions.

TAG	QTY.	SIZE		FRAME	VARIATIONS
		A*-WIDE	B*-HIGH		
PROJECT	 <p>WebREPS 800-810-3280</p>	LOCATION		CONTRACTOR	DATE
ARCH./ENGR.		CONTRACTOR			
REPRESENTATIVE		DATE			

TYPICAL INSTALLATION DETAILS

Masonry Wall

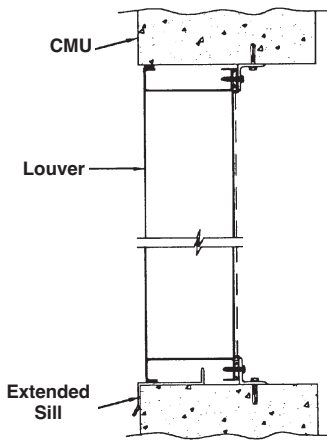

Metal Panel Wall

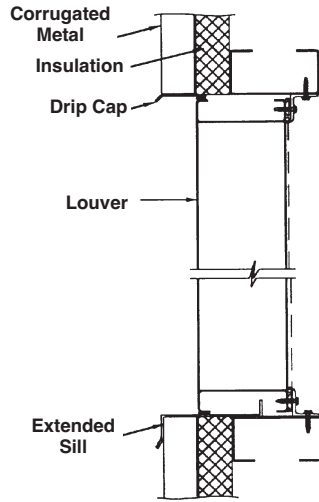

Flange Mount

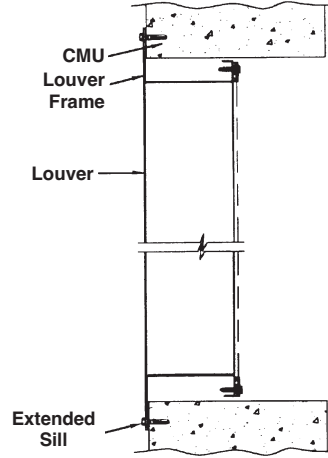

Angle Subframe

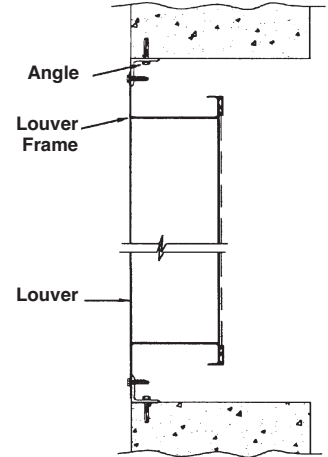

STANDARD CONSTRUCTION DETAILS

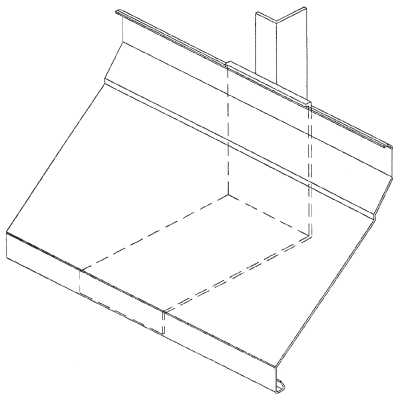

Hidden Vertical Blade Support (HVBS)

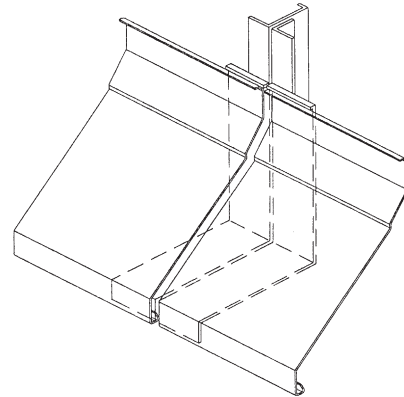

Continuous Blade Appearance at Multiple Section Junctions

PRESSURE DROP

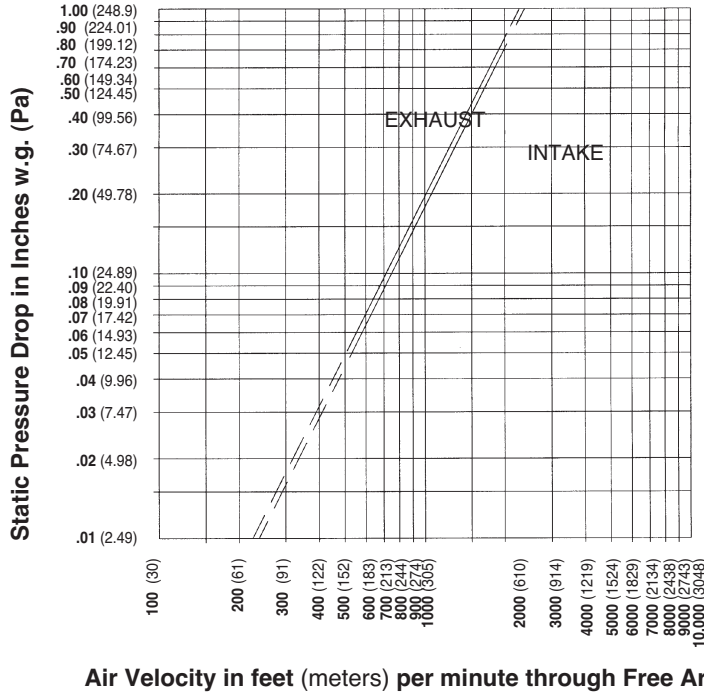

Ratings do not include the effect of a bird screen.

WATER PENETRATION GRAPH

Test size 48" wide x 48" high (1219 x 1219)

Beginning point of water penetration at .01 oz./sq. ft. is 725fpm (221 m/min).

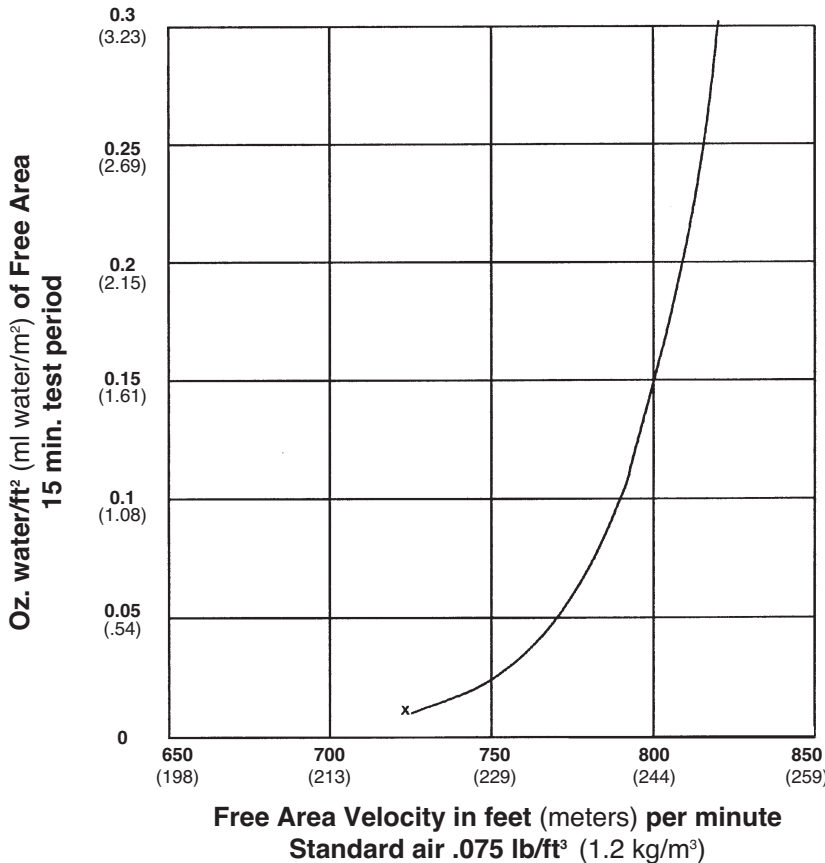

Reliable Products certifies that the 445FB Louvers shown herein are licensed to bear the AMCA Seal. The ratings shown are based on tests and procedures performed in accordance with AMCA Publication 511 and comply with the requirements of the AMCA Certified Ratings Program. The AMCA Certified Ratings Seal applies to air performance ratings and water penetration ratings only.

SUGGESTED SPECIFICATION

Furnish and install louvers as hereinafter specified where shown on plans or as described in schedules. Louvers shall be stationary type entirely contained within a 4" (102) frame. Louver components (heads, jambs, sills, blades, & mullions) shall be factory assembled by the louver manufacturer. Louver sizes too large for shipping shall be built up by the contractor from factory assembled louver sections to provide overall sizes required. Louver design shall incorporate structural supports required to withstand a wind load of 20 lbs. per sq. ft. (.96kPa) (equivalent of a 90 mph wind [145 KPH] – specifier may substitute any loading required).

Louvers shall be Reliable Model 445FB construction as follows:

- Frame: 18 gage (1.3) galvanized steel.
- Blades: 20 gage (1.0) galvanized steel at 45° angle on approximately 5" (127) center to center.
- Screen: 1/2" mesh x 19 gage (13 x 1.1) galvanized in removable frame.
- Finish: Select finish specification from Reliable/Valspar Finishes Brochure.

Published louver performance data bearing the AMCA Certified Ratings Seal for Air Performance & Water Penetration must be submitted for approval prior to fabrication and must demonstrate pressure drop and water penetration equal to or less than the Reliable model specified.

PERFORMANCE DATA

AMCA Standard 500 provides a reasonable basis for testing and rating louvers. Testing to AMCA 500 is performed under a certain set of laboratory conditions. This does not guarantee that other conditions will not occur in the actual environment where louvers must operate.

Designs should provide a reasonable safety factor for louver performance by selecting at some point below pressure drop or water penetration system requirements.

FREE AREA GUIDE

Free Area Guide shows free area in ft² and m² for various sizes of 445FB
Width – Inches and Meters

Height – Inches and Meters

	12	18	24	30	36	42	48	54	60	66	72	78	84	90
	0.30	0.46	0.61	0.76	0.91	1.07	1.22	1.37	1.52	1.68	1.83	1.98	2.13	2.29
12	0.32	0.51	0.71	0.90	1.10	1.29	1.48	1.68	1.87	2.07	2.26	2.45	2.65	2.84
0.30	0.03	0.05	0.07	0.08	0.10	0.12	0.14	0.16	0.17	0.19	0.21	0.23	0.25	0.26
18	0.42	0.68	0.93	1.19	1.44	1.70	1.95	2.21	2.46	2.72	2.97	3.23	3.48	3.74
0.46	0.04	0.06	0.09	0.11	0.13	0.16	0.18	0.21	0.23	0.25	0.28	0.30	0.32	0.35
24	0.68	1.09	1.50	1.91	2.32	2.73	3.14	3.55	3.96	4.37	4.79	5.20	5.61	6.02
0.61	0.06	0.10	0.14	0.18	0.22	0.25	0.29	0.33	0.37	0.41	0.45	0.48	0.52	0.56
30	0.93	1.50	2.07	2.63	3.20	3.77	4.33	4.90	5.46	6.03	6.60	7.16	7.73	8.30
0.76	0.09	0.14	0.19	0.24	0.30	0.35	0.40	0.46	0.51	0.56	0.61	0.67	0.72	0.77
36	1.19	1.91	2.63	3.35	4.08	4.80	5.52	6.24	6.97	7.69	8.41	9.13	9.85	10.58
0.91	0.11	0.18	0.24	0.31	0.38	0.45	0.51	0.58	0.65	0.71	0.78	0.85	0.92	0.98
42	1.44	2.32	3.20	4.08	4.96	5.83	6.71	7.59	8.47	9.34	10.22	11.10	11.98	12.86
1.07	0.06	0.09	0.13	0.16	0.20	0.23	0.26	0.30	0.33	0.37	0.40	0.44	0.47	0.51
48	1.55	2.48	3.42	4.36	5.30	6.24	7.18	8.12	9.06	10.00	10.93	11.87	12.81	13.75
1.22	0.14	0.23	0.32	0.41	0.49	0.58	0.67	0.75	0.84	0.93	1.02	1.10	1.19	1.28
54	1.80	2.90	3.99	5.08	6.18	7.27	8.37	9.46	10.56	11.65	12.75	13.84	14.94	16.03
1.37	0.17	0.27	0.37	0.47	0.57	0.68	0.78	0.88	0.98	1.08	1.19	1.29	1.39	1.49
60	2.06	3.31	4.56	5.81	7.06	8.31	9.56	10.81	12.06	13.31	14.56	15.81	17.06	18.31
1.52	0.19	0.31	0.42	0.54	0.66	0.77	0.89	1.01	1.12	1.24	1.35	1.47	1.59	1.70
66	2.31	3.72	5.13	6.53	7.94	9.34	10.75	12.15	13.56	14.97	16.37	17.78	19.18	20.59
1.68	0.22	0.35	0.48	0.61	0.74	0.87	1.00	1.13	1.26	1.39	1.52	1.65	1.78	1.91
72	2.57	4.13	5.69	7.25	8.81	10.38	11.94	13.50	15.06	16.62	18.18	19.74	21.31	22.87
1.83	0.24	0.38	0.53	0.67	0.82	0.96	1.11	1.26	1.40	1.55	1.69	1.84	1.98	2.13
78	2.67	4.29	5.92	7.54	9.16	10.78	12.41	14.03	15.65	17.27	18.90	20.52	22.14	23.76
1.98	0.25	0.40	0.55	0.70	0.85	1.00	1.15	1.30	1.46	1.61	1.76	1.91	2.06	2.21
84	2.93	4.70	6.48	8.26	10.04	11.82	13.60	15.37	17.15	18.93	20.71	22.49	24.26	26.04
2.13	0.27	0.44	0.60	0.77	0.93	1.10	1.26	1.43	1.60	1.76	1.93	2.09	2.26	2.42
90	3.18	5.12	7.05	8.98	10.92	12.85	14.78	16.72	18.65	20.59	22.52	24.45	26.39	28.32
2.29	0.30	0.48	0.66	0.84	1.02	1.20	1.37	1.55	1.73	1.91	2.09	2.27	2.45	2.63
96	3.44	5.53	7.62	9.71	11.80	13.89	15.97	18.06	20.15	22.24	24.33	26.42	28.51	30.60
2.44	0.32	0.51	0.71	0.90	1.10	1.29	1.49	1.68	1.87	2.07	2.26	2.46	2.65	2.85
102	3.69	5.94	8.18	10.43	12.67	14.92	17.16	19.41	21.65	23.90	26.14	28.39	30.63	32.88
2.59	0.34	0.55	0.76	0.97	1.18	1.39	1.60	1.81	2.01	2.22	2.43	2.64	2.85	3.06
108	3.80	6.10	8.41	10.71	13.02	15.33	17.63	19.94	22.24	24.55	26.86	29.16	31.47	33.78
2.74	0.35	0.57	0.78	1.00	1.21	1.43	1.64	1.85	2.07	2.28	2.50	2.71	2.93	3.14
114	4.05	6.51	8.98	11.44	13.90	16.36	18.82	21.28	23.75	26.21	28.67	31.13	33.59	36.05
2.90	0.38	0.61	0.83	1.06	1.29	1.52	1.75	1.98	2.21	2.44	2.67	2.90	3.12	3.35
120	4.31	6.93	9.54	12.16	14.78	17.39	20.01	22.63	25.25	27.86	30.48	33.10	35.72	38.33
3.05	0.40	0.64	0.89	1.13	1.37	1.62	1.86	2.10	2.35	2.59	2.83	3.08	3.32	3.56