

Model DH70 & DH95

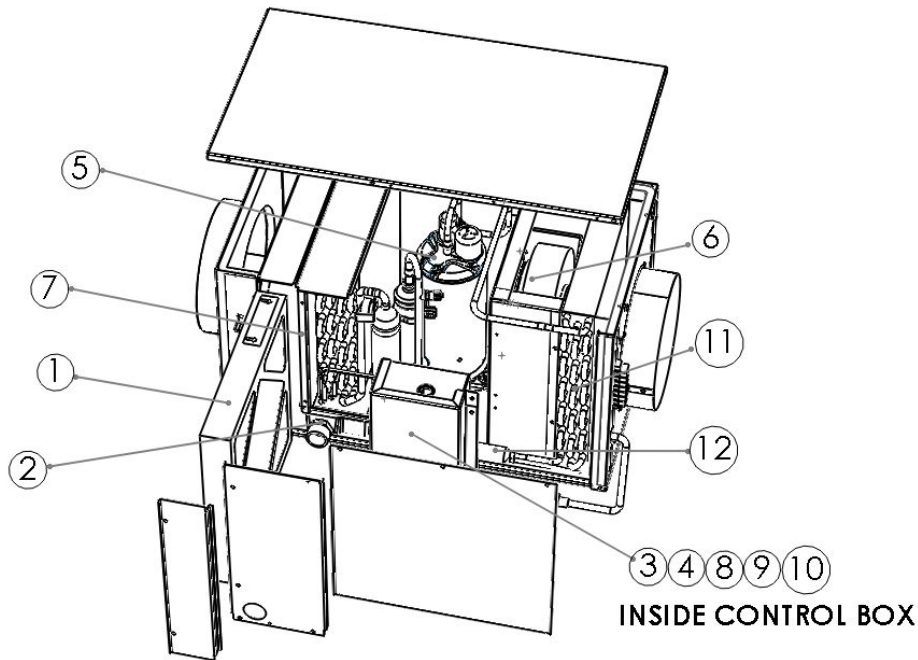

Dehumidifier Replacement Parts

	Qty. Req'd	GFI #	Part Description
1	1	7133	MERV 11 Replacement Filter for DH70
2	1	6500	100-1001 DRAIN PAN, BLK For DH70
3	1	6502	100-1560 RUN CAPACITOR, 35/370(-50) For DH70
4	1	6503	100-1570 CAPACITOR 5MF/440V OVAL For DH70
5	1	6504	100-1600 COMPRESSOR RGA5471BAA For DH70
6	1	6505	100-4022 BLOWER, 115 VOLT For DH70
7	1	6506	100A3013 EVAPORATOR COIL For DH70
8	1	6507	150-1544 15 AMP 2PDP 24V RELAY (SUB FOR 150-1542) For DH70
9	1	6508	150-1545 FLANGE MOUNT FOR 1501544 RELAY For DH70
10	1	6510	150-1530 TRANSFORMER, 120.24V 20 VA For DH70
11	1	6511	100-3015 CONDENSOR COIL, For DH70
12	1	6512	100-3022 STRAINER ASSEMBLY, For DH70
Parts Not Shown			
	1	6509	400-3026 FREEZE STAT For DH70
	1	7134	MERV 11 Replacement Filter for Dehumidifier For DH95
	1	6700	200-1001 DRAIN PAN For DH95
	1	6702	200-1542 RELAY, 30A, 2PDT 24V COIL - Relay For DH95
	1	6703	200-1570 CAPACITOR 7.5MFD/440 OVL For DH95
	1	6704	200-1600 RG133AR-502-A41V COMPRESSOR For DH95
	1	6705	200-3013 EVAPORATOR COIL DH95 For DH95
	1	6706	200-3015 CONDENSER FOR DH95 For DH95
	1	6707	200-3022 STRAINER, CAP TUBE ASSEMBLY For DH95
	1	6708	200-4022 BLOWER, 115V, BACKWARD CUR For DH95