

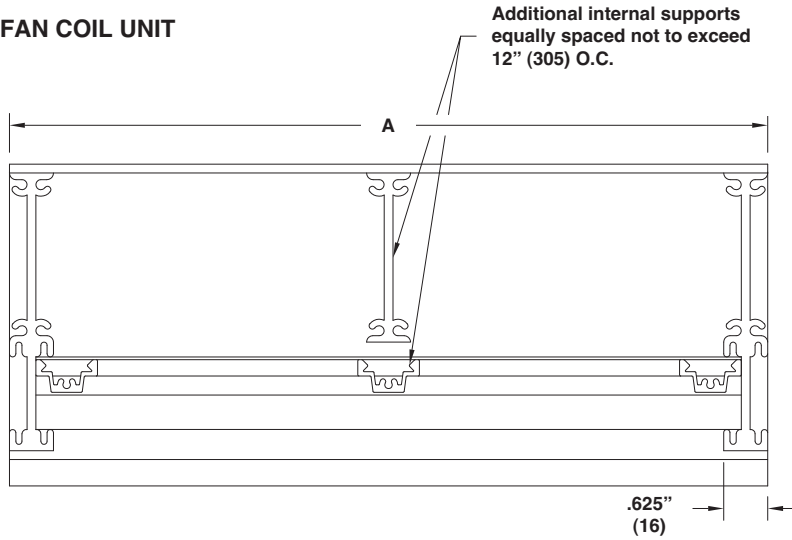

XHD-AEL-42

FAN COIL UNIT



STANDARD CONSTRUCTION

- Extruded aluminum; 6063-T5

OPTIONS

- Clear or anodized finish
- Prime coat
- Baked Enamel (Kynar 50%)
- Pearledized 50 or 70
- Kynar 70%

Notes:

1. Face view for illustration purposes only
2. Dimensions in inches, parenthesis () indicate millimeters

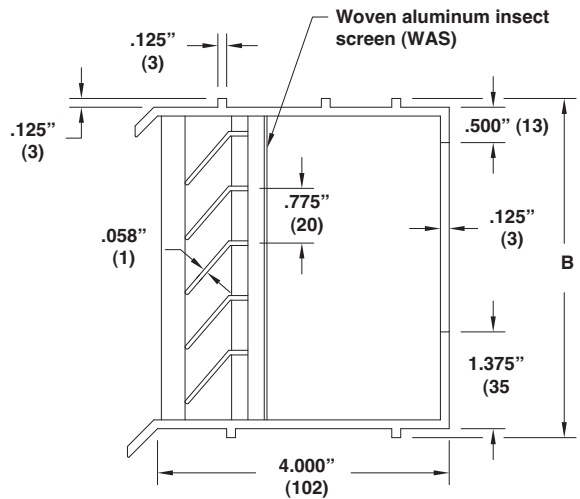
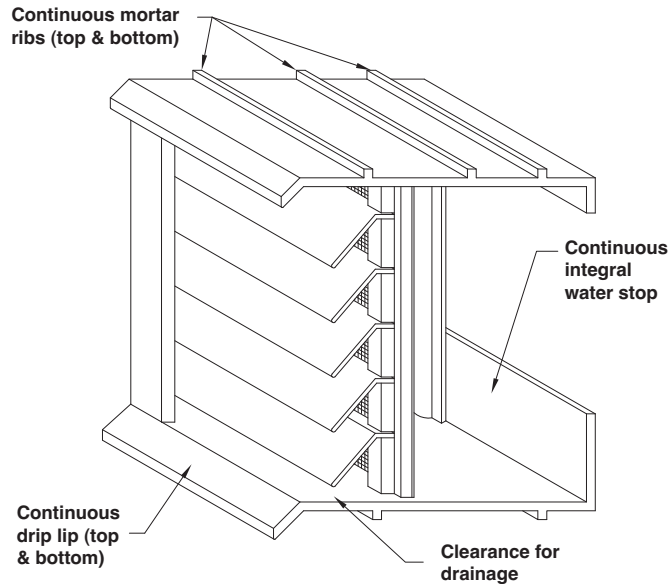

UNIT TYPE	UNIT MODEL NO.	ACTUAL SIZE		VARIATIONS
		A	B	
PROJECT ARCH./ENGR. REPRESENTATIVE	 WebREPS 1-800-810-3280	LOCATION CONTRACTOR DATE		



XHD-AEL-42 W/ 34 FRAME

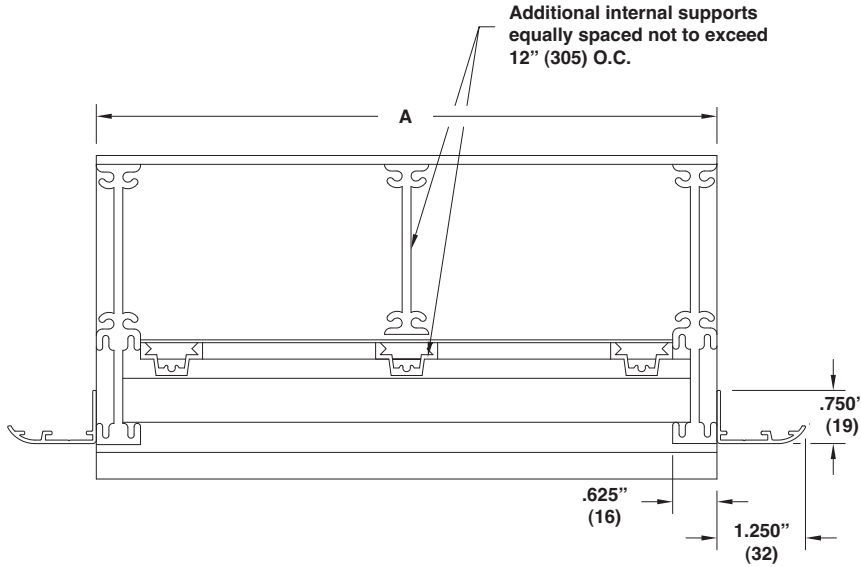

STANDARD CONSTRUCTION

- Extruded aluminum; 6063-T5

OPTIONS

- Clear or anodized finish
- Prime coat
- Baked Enamel (Kynar 50%)
- Pearledized 50 or 70
- Kynar 70%

Notes:

1. Face view for illustration purposes only
2. Dimensions in inches, parenthesis () indicate millimeters

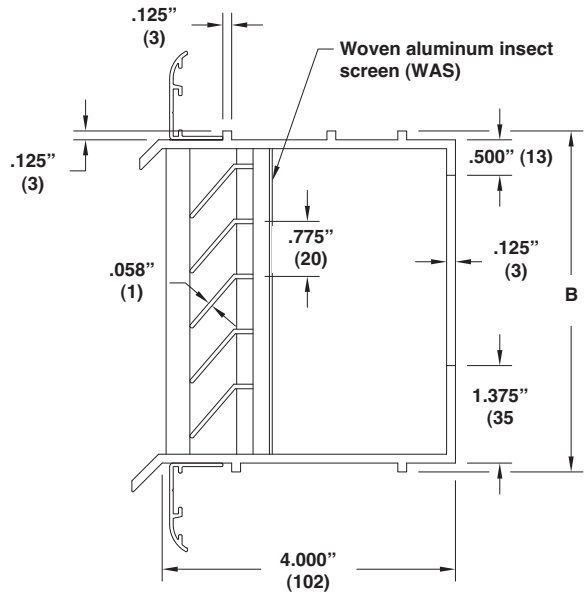
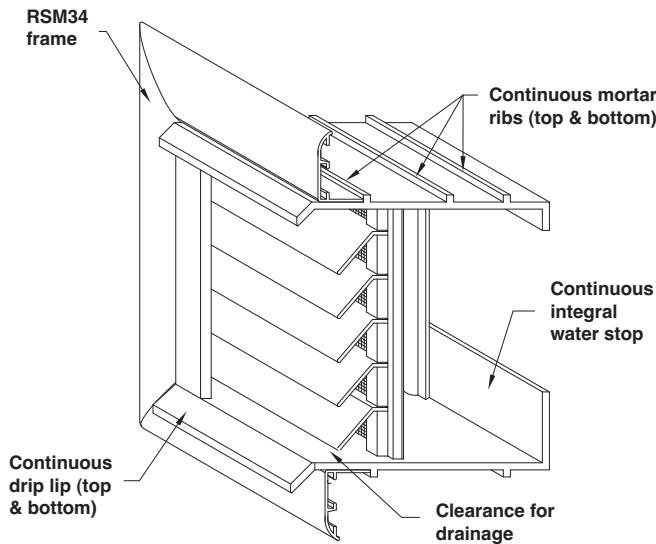

UNIT TYPE	UNIT MODEL NO.	ACTUAL SIZE		VARIATIONS
		A	B	
PROJECT ARCH./ENGR. REPRESENTATIVE	 WebREPS 1-800-810-3280	LOCATION CONTRACTOR DATE		



1300 ENTERPRISE ROAD GENEVA, ALABAMA 36340-0580 800-239-4621 FAX 1-800-508-1469 www.reliablelouvers.com

RBV7020-4 / RBV7020-8 (BRICK/BLOCK VENTS)

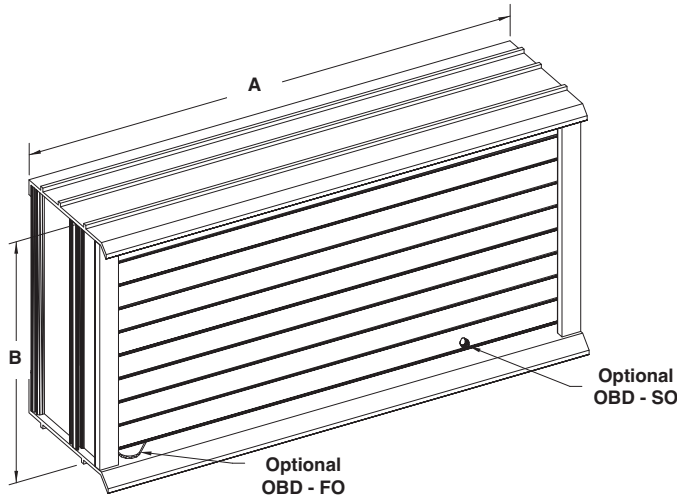

STANDARD CONSTRUCTION

- Brick and block vents in 2 standard depths, 4" (102) and 8" (203)
- Special design features afford maximum weather protection
- .125" (3) extruded aluminum construction; 6063-T5 alloy
- Clear anodized finish is standard. Call factory for other available finishes.

OPTIONS

- Opposed blade damper.
Specify: Face operator Slot operator
- Sleeve extension
 Specify total depth: _____ inches

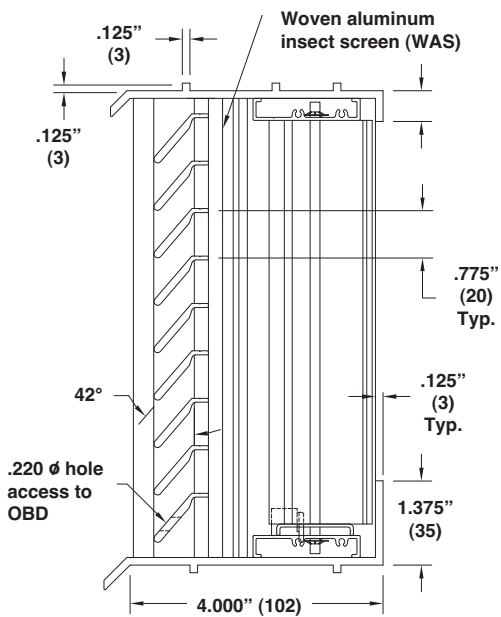

RBV7020-4 OBD
Shown with optional OBD-SO

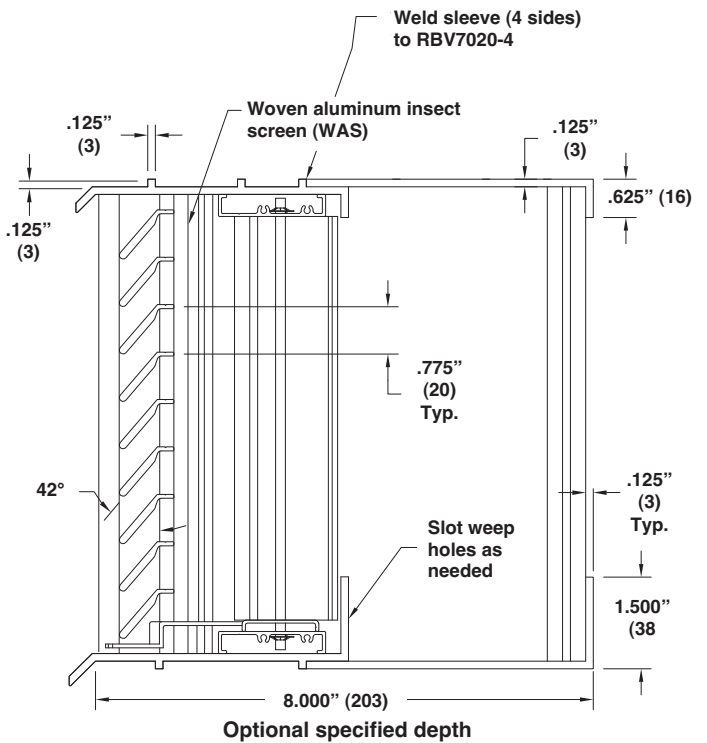

Optional specified depth

Note: Dimensions in inches, parenthesis () indicate millimeters

UNIT TYPE	UNIT MODEL NO.	VARIATIONS
PROJECT ARCH./ENGR. REPRESENTATIVE	 WebREPS 1-800-810-3280	LOCATION CONTRACTOR DATE



RBV7020-4FF / RBV7020-8FF

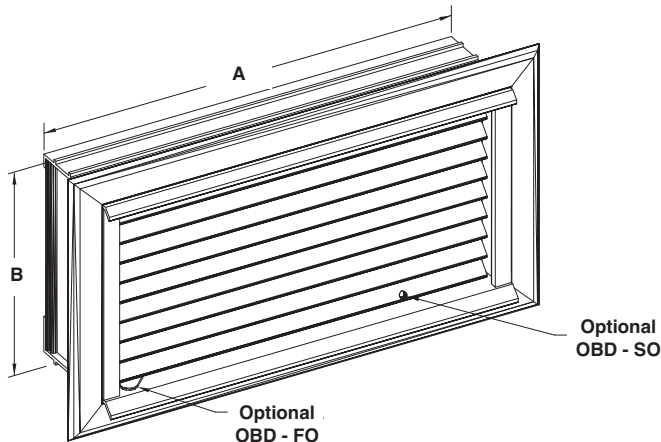

STANDARD CONSTRUCTION

- Brick and block vents in 34 flange frame in 2 standard depths, 4" (102) and 8" (203)
- Special design features afford maximum weather protection
- .125" (3) extruded aluminum; 6063-T5 alloy

OPTIONS

- Opposed blade damper.
Specify: Face operator Slot operator
- Sleeve extension: Specify total depth: _____ inches

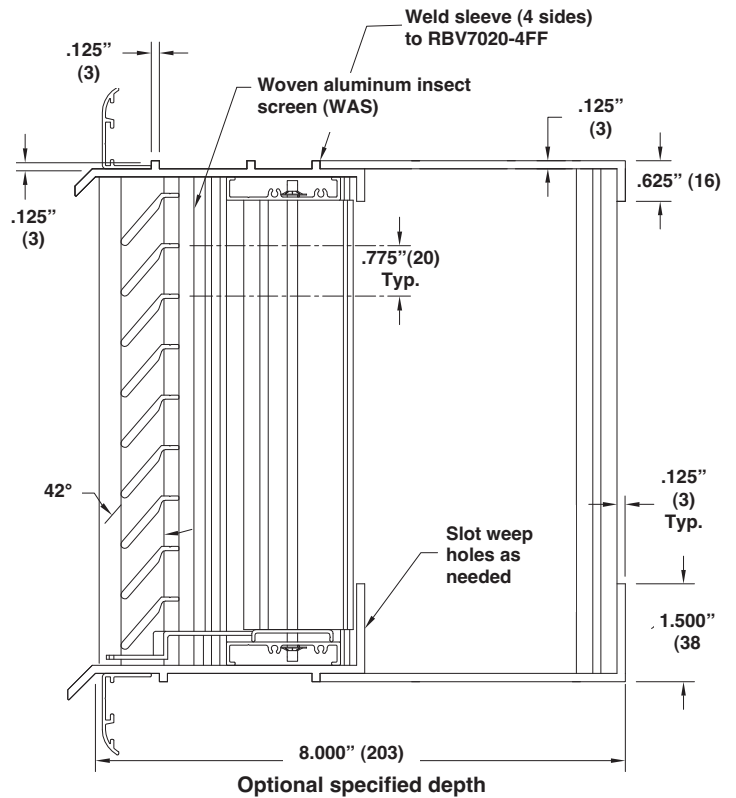
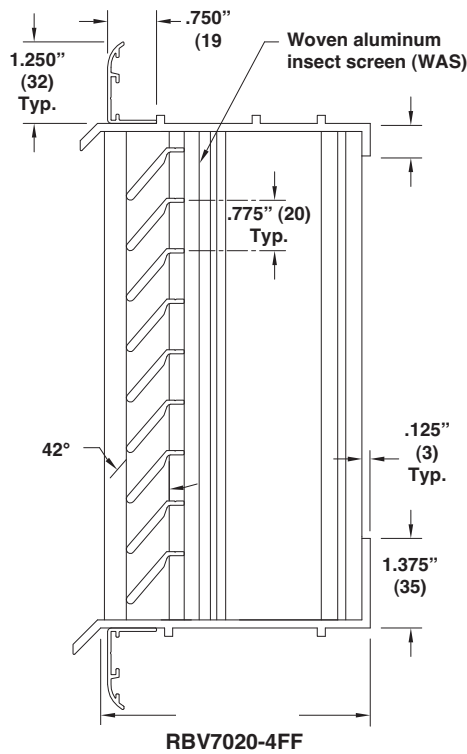

Note: Dimensions in inches, parenthesis () indicate millimeters

UNIT TYPE	UNIT MODEL NO.	VARIATIONS
PROJECT ARCH./ENGR. REPRESENTATIVE	 WebREPS 1-800-810-3280	LOCATION CONTRACTOR DATE



RBV7020-FF

STANDARD CONSTRUCTION

- Brick and block vents in 1" (25) depth
- Special design features afford maximum weather protection
- .125" (3) extruded aluminum construction; 6063-T5 alloy
- Clear anodized finish is standard. Call factory for other available finishes

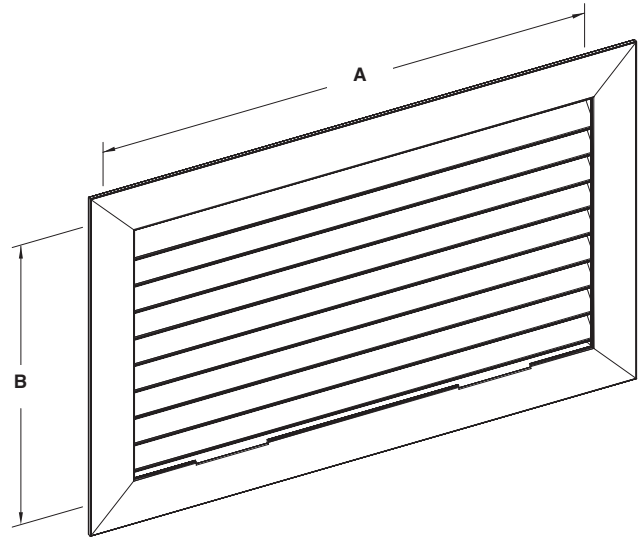
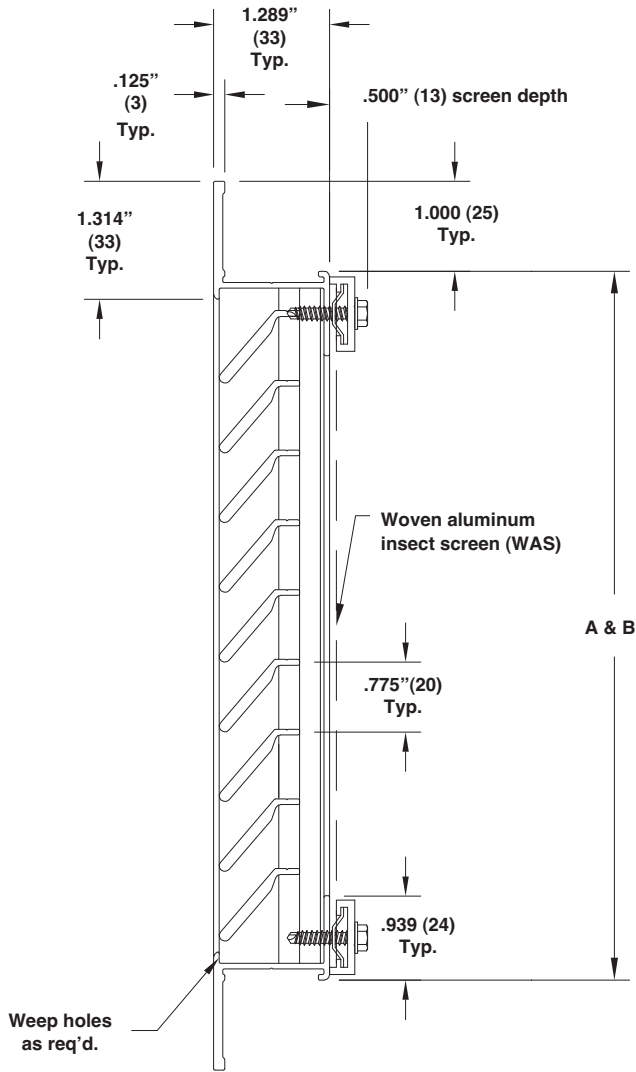

Note: Dimensions in inches, parenthesis () indicate millimeters

UNIT TYPE	UNIT MODEL NO.	VARIATIONS
PROJECT ARCH./ENGR. REPRESENTATIVE	 WebREPS 1-800-810-3280	LOCATION CONTRACTOR DATE

EXTRUDED ALUMINUM BRICK VENTS

Model 1-BVF

STORM RESISTANT
(FLANGED)

FRAME:

1/8" THICK EXTRUDED
ALUMINUM 6063 T6
CONSTRUCTION WITH 1"
WALL FLANGE

BLADES:

1/8" THICK EXTRUDED
ALUMINUM 6063 T6
CONSTRUCTION

BLADE CENTERS:

1" CENTERS AT 45°
HEAD AND SILL SPACING NOT
TO EXCEED FRAME FLANGE
DIMENSION FOR MAXIMUM
WATER RESISTANCE

ASSEMBLY:

FASTENED WITH CORROSION
RESISTANT BOLTS

INSECT SCREEN:

ALUMINUM 18 X 16 MESH
CORROSION RESISTANT

FINISH:

MILL FINISH

*OPTIONAL FINISH:

- (1) CLEAR ANODIZE
- (2) PAINTED
- (3) "KYNAR"
- (4) ANODIZE COLORS

SIZES:

MINIMUM WIDTH 4"
MINIMUM HEIGHT 2-1/4"
MAXIMUM SINGLE SECTION
UNLIMITED

DELIVERY:

CONSULT FACTORY

BRICK VENTS WILL BE SUPPLIED AS ORDER WIDTH -1/4" X ORDER HEIGHT -1/4" UNLESS SPECIFIED 'ACTUAL SIZE'

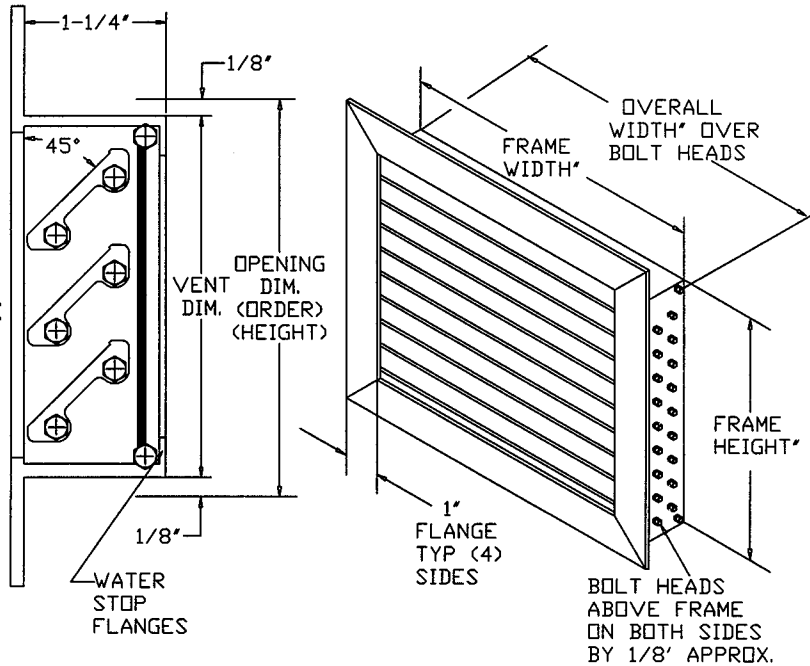
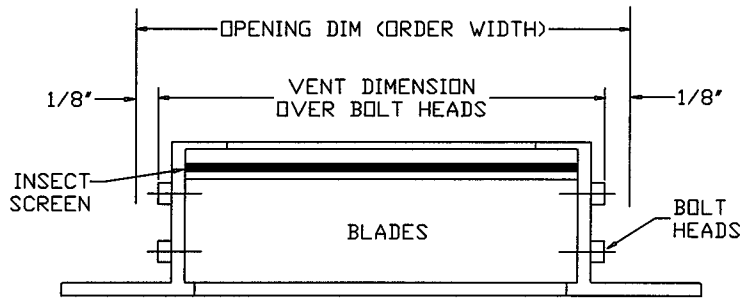

MARK	QUAN.	WIDTH	HEIGHT	JOB NAME:

JOB NAME: _____

LOCATION: _____

ARCHITECT: _____

ENGINEER: _____

CONTRACTOR: _____



10195-REV-A-1

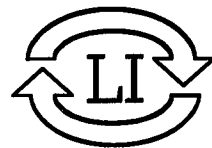

LLOYD INDUSTRIES INC.

231 COMMERCE DRIVE
MONTGOMERYVILLE, PA. 18936
TEL: 215-412-4445
FAX: 215-412-4409
EMAIL: LLOYDIND@FIREDAMPER.COM

5858 BROADWAY AVE.
JACKSONVILLE, FL. 32254
TEL: 904-378-8440
FAX: 904-378-8441
EMAIL: LLOYDINDI@BELLSOUTH.NET

WEB SITE: FIREDAMPER.COM

EXTRUDED ALUMINUM BRICK VENTS

FRAME:

1/8" THICK EXTRUDED ALUMINUM 6063 T6 CONSTRUCTION WITH 1/4" DRIP LEDGE TOP AND BOTTOM

BLADES:

1/8" THICK EXTRUDED ALUMINUM 6063 T6 CONSTRUCTION

BLADE CENTERS:

1" CENTERS AT 45° HEAD AND SILL SPACING NOT TO EXCEED FRAME FLANGE DIMENSION FOR MAXIMUM WATER RESISTANCE

ASSEMBLY:

FASTENED WITH CORROSION RESISTANT BOLTS

INSECT SCREEN:

ALUMINUM 18 X 16 MESH CORROSION RESISTANT

FINISH:

MILL FINISH

*OPTIONAL FINISH:

- (1) CLEAR ANODIZE
- (2) PAINTED
- (3) "KYNAR"
- (4) ANODIZE COLORS

SIZES:

MINIMUM WIDTH 4"
MINIMUM HEIGHT 2-1/4"
MAXIMUM SINGLE SECTION UNLIMITED

DELIVERY:

CONSULT FACTORY

Model 4-BVCF

STORM RESISTANT
(CHANNEL FRAME)

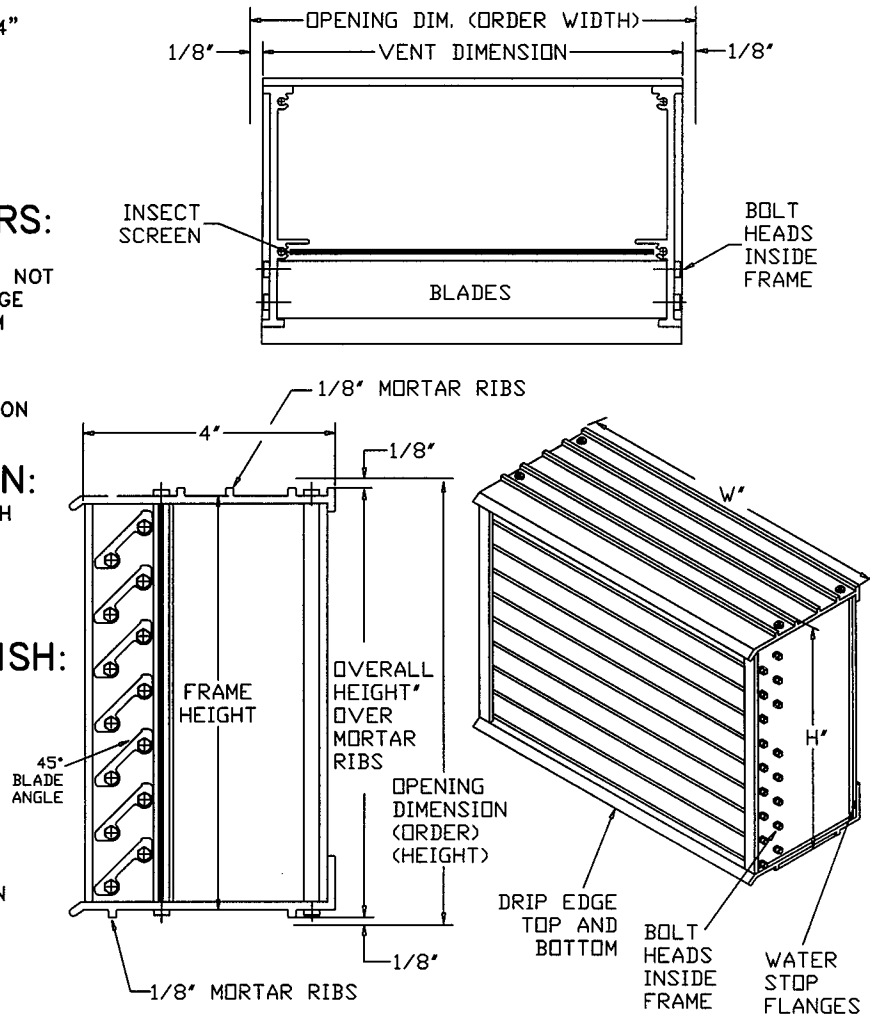

BRICK VENTS WILL BE SUPPLIED AS ORDER WIDTH -1/4" X ORDER HEIGHT -1/4" UNLESS SPECIFIED 'ACTUAL SIZE'

MARK	QUAN.	WIDTH	HEIGHT	JOB NAME:
				LOCATION:
				ARCHITECT:
				ENGINEER:  1-800-810-3280
				CONTRACTOR:

10195-REV-A-2

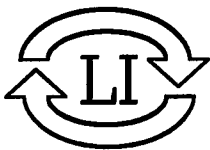

LLOYD INDUSTRIES INC.

231 COMMERCE DRIVE
MONTGOMERYVILLE, PA. 18936
TEL: 215-412-4445
FAX: 215-412-4409
EMAIL: LLOYDIND@FIREDAMPER.COM

5858 BROADWAY AVE.
JACKSONVILLE, FL. 32254
TEL: 904-378-8440
FAX: 904-378-8441
EMAIL: LLOYDINDI@BELLSOUTH.NET

WEB SITE: FIREDAMPER.COM