



## FRAMES ARCHITECTURAL FRAMES FOR AEL SERIES LOUVERS

### OPTIONS

- Clear or anodized finish
- Prime coat
- Baked Enamel (Kynar 50%)
- Pearledized 50 or 70
- Kynar 70%

### Flange Type Frames

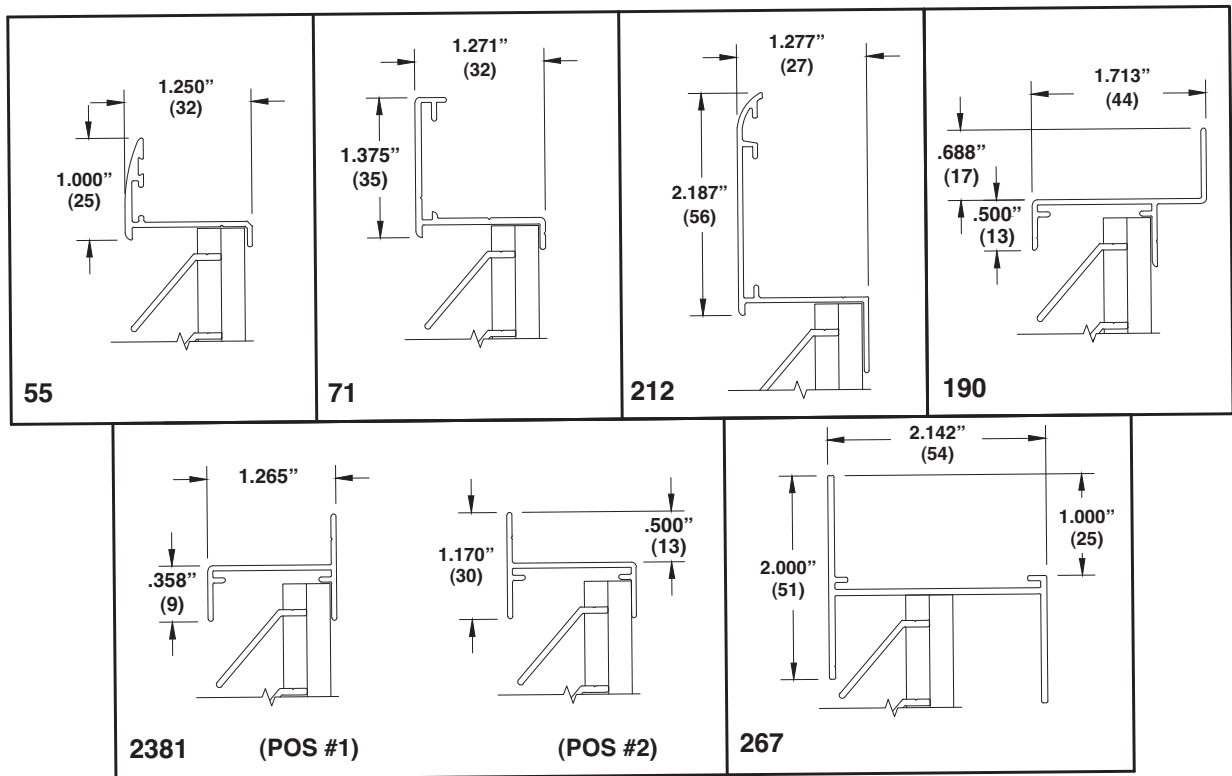

**Note:** Dimensions in inches, parenthesis ( ) indicate millimeters

ANY COMBINATION OF AEL LOUVERS AND FRAMES FOR USE WITH WALL AND WINDOW SECTIONS

See Pages 3 thru 7 for louver Blade Choices

<p><b>PROJECT</b> ARCH./ENGR. REPRESENTATIVE</p>	 <b>WebREPS</b> 1-800-810-3280	<p><b>LOCATION</b> CONTRACTOR DATE</p>
--	---	--



1300 ENTERPRISE ROAD GENEVA, ALABAMA 36340-0580 800-239-4621 FAX 1-800-508-1469 www.reliablelouvers.com

## FRAMES

### ARCHITECTURAL FRAMES FOR AEL SERIES LOUVERS

  
**WebREPS**  
 1-800-810-3280

#### OPTIONS

- Clear or anodized finish    
  Prime coat    
  Baked Enamel (Kynar 50%)    
  Pearledized 50 or 70    
  Kynar 70%

### Channel Type Frames

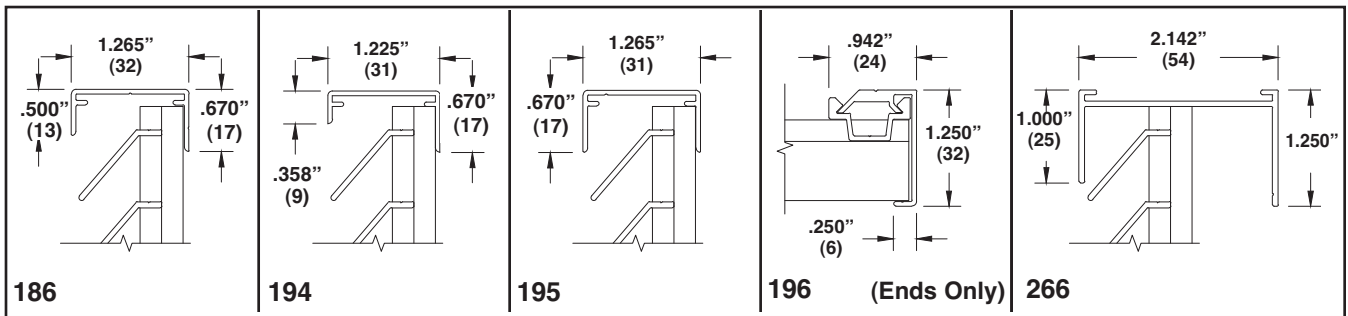

### Glazing Type Frames

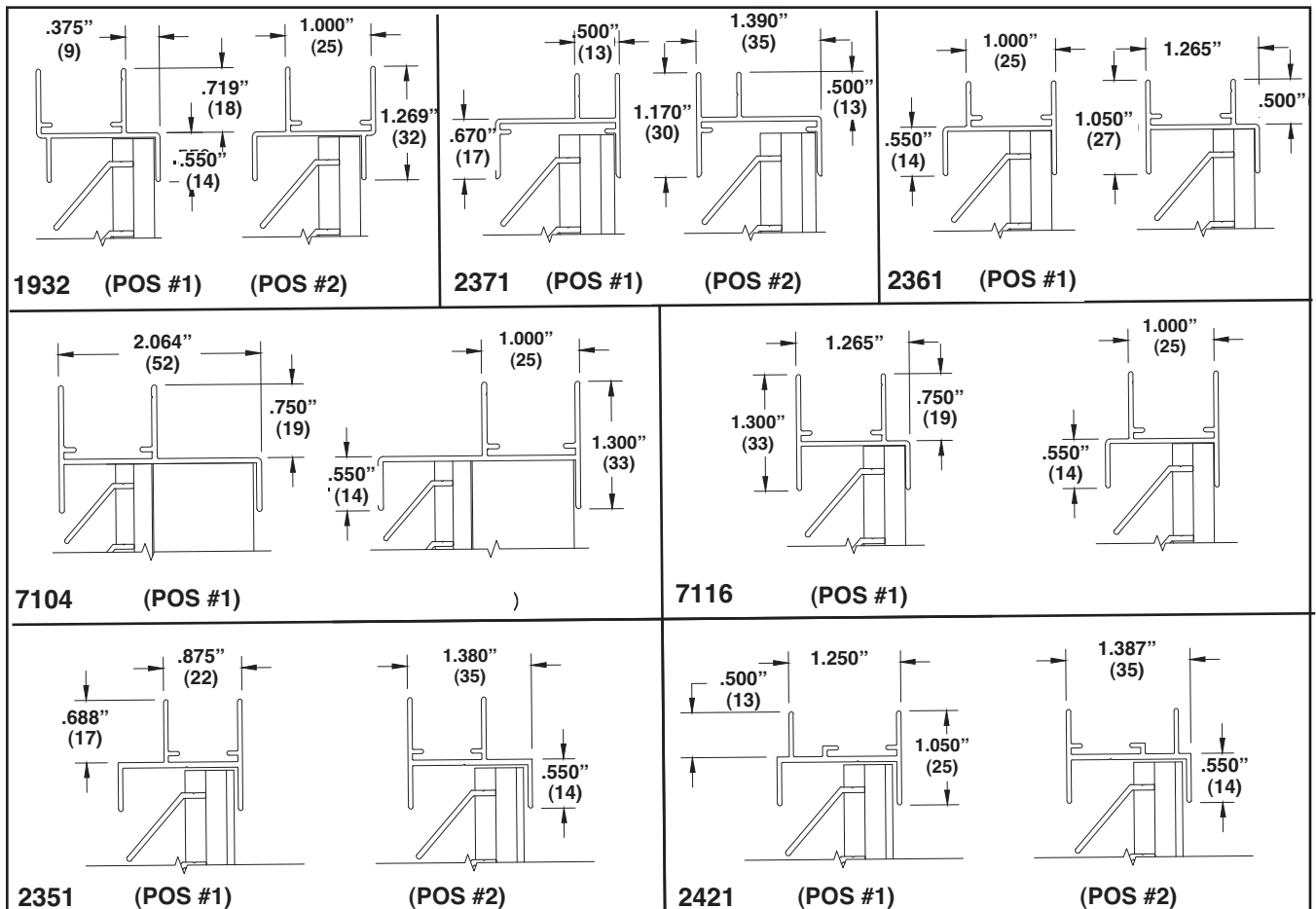

**Note:** Dimensions in inches, parenthesis ( ) indicate millimeters

**ANY COMBINATION OF AEL LOUVERS AND FRAMES FOR USE WITH WALL AND WINDOW SECTIONS**



## INTERIOR TRIM FRAMES

### OPTIONS

- Clear or anodized finish
- Prime coat
- Baked Enamel (Kynar 50%)
- Pearledized 50 or 70
- Kynar 70%

### Architectural Interior Frames

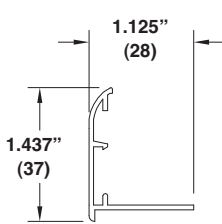
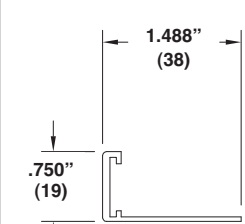
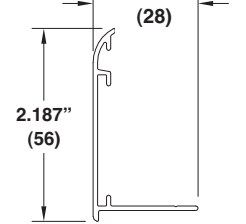
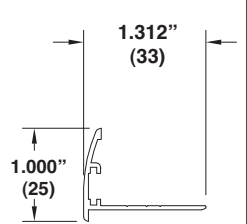
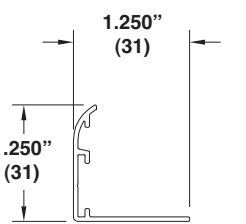
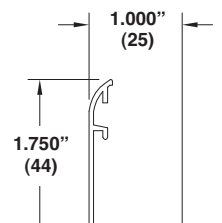
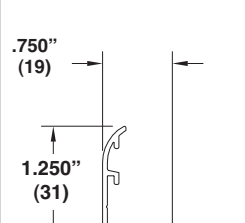
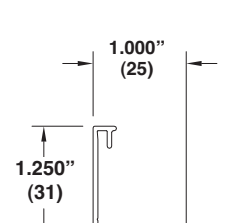
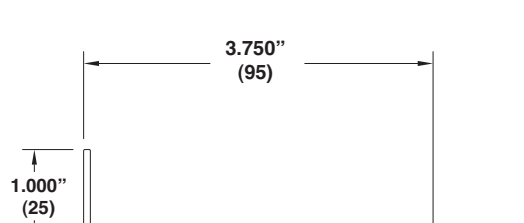
 <p><b>351</b></p>	 <p><b>216</b></p>	 <p><b>210</b></p>	 <p><b>104</b></p>	 <p><b>20</b></p>
 <p><b>172</b></p>	 <p><b>34</b></p>	 <p><b>3</b></p>	 <p><b>151</b></p>	

**Note:** Dimensions in inches, parenthesis ( ) indicate millimeters

**PROJECT**  
**ARCH./ENGR.**  
**REPRESENTATIVE**



**LOCATION**  
**CONTRACTOR**  
**DATE**



AEL - 42

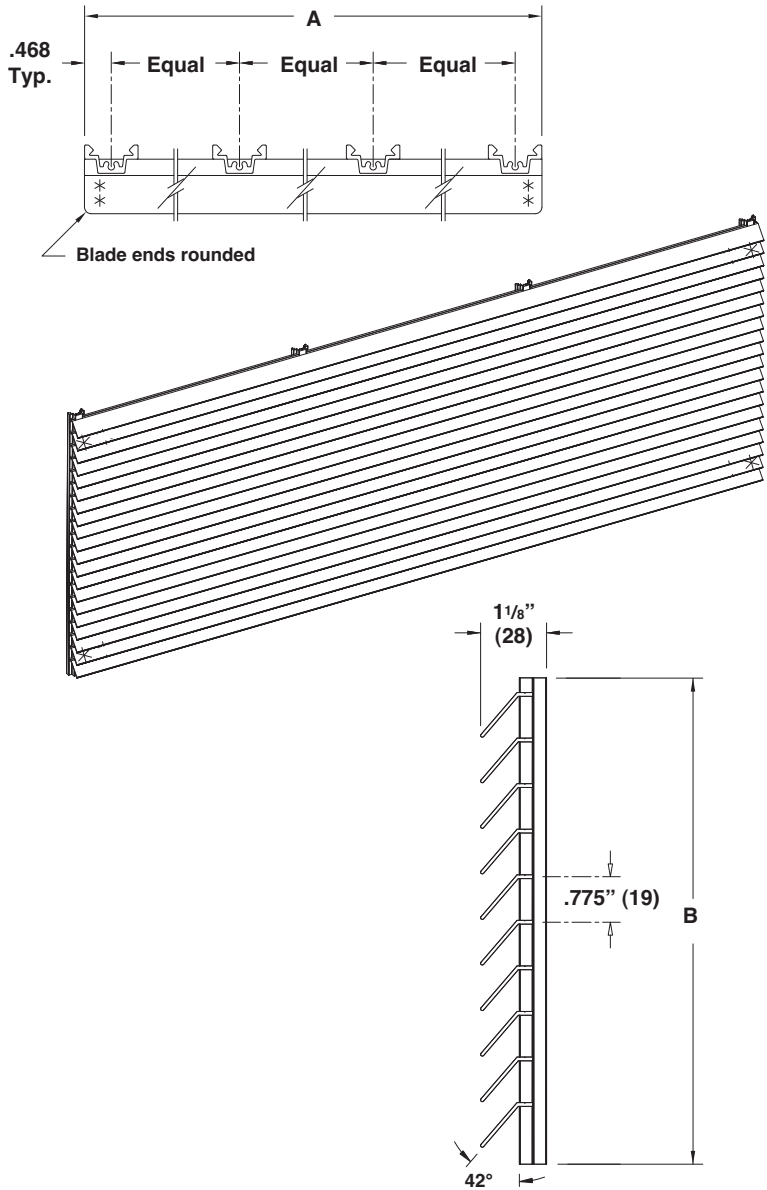

**STANDARD CONSTRUCTION**

**FRAME**

Extruded aluminum; 6063-T5; clear.  
 Anodized or \_\_\_\_\_  
 42° architectural decorative louver face and end views for illustration purposes only.  
 A = \_\_\_\_\_  
 B = \_\_\_\_\_  
 A as required, not to exceed 180" (4512).  
 B as required, not to exceed 84" (2134).  
 Brace bar as required, not to exceed 16" (406).

**BLADES**

Standard blade thickness .040 with a variety of perimeter frames available. Heavier blades available. Although the AEL-42 is primarily used in PTAC applications, it can also be constructed as a mechanical screen or a variety of aesthetic pleasing thinline applications.

**VARIATIONS**

Variations to the basic design of the louver are available at additional cost. They include:

- Frames of choice, see frame submittal sheet.
- 1" (25) blade spacing.
- Exterior mounting holes as required.

\*Consult Reliable for other special requirements.

Dimensions in inches, parenthesis ( ) indicate millimeters.

TAG	QTY.	ACTUAL SIZE		FRAME	VARIATIONS
		A*-WIDE	B*-HIGH		
PROJECT ARCH./ENGR. REPRESENTATIVE		 WebREPS 1-800-810-3280		LOCATION CONTRACTOR DATE	



1300 ENTERPRISE ROAD GENEVA, ALABAMA 36340-0580 800-239-4621 FAX 1-800-508-1469 www.reliablelouvers.com

### AEL - 30

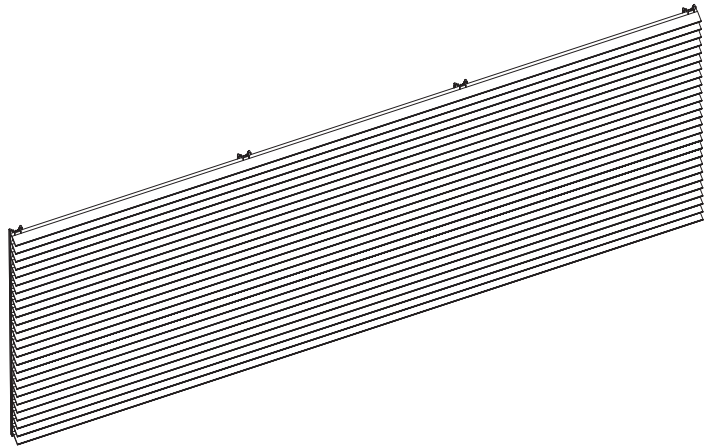
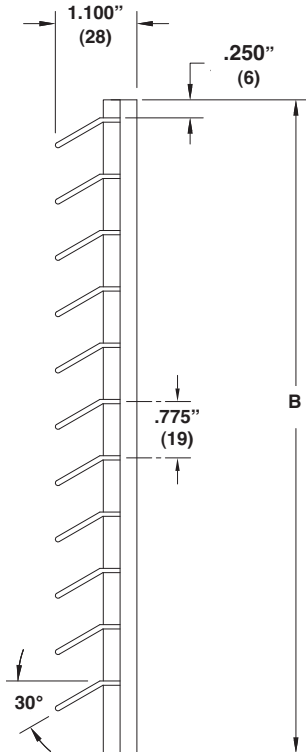
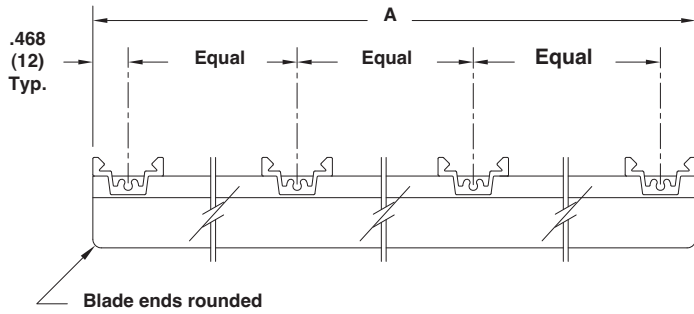

#### STANDARD CONSTRUCTION

- Extruded aluminum; 6063-T5
- 30° architectural decorative louver

#### OPTIONS

- Clear or anodized finish
- Prime coat
- Baked Enamel (Kynar 50%)
- Pearledized 50 or 70
- Kynar 70%
- Frames of choice - see frame submittal sheet

#### VARIATIONS

- A as required, not to exceed 190" (4826)
- B as required, not to exceed 84" (2134)
- Brace bar as required, not to exceed 16" (406)

#### Notes:

1. Face view for illustration purposes only.
2. Dimensions in inches, parenthesis ( ) indicate millimeters.

QTY.	ACTUAL SIZE		VARIATIONS
	A	B	
<b>PROJECT ARCH./ENGR. REPRESENTATIVE</b>	 <b>WebREPS</b> 1-800-810-3280		<b>LOCATION CONTRACTOR DATE</b>



### AEL - 45

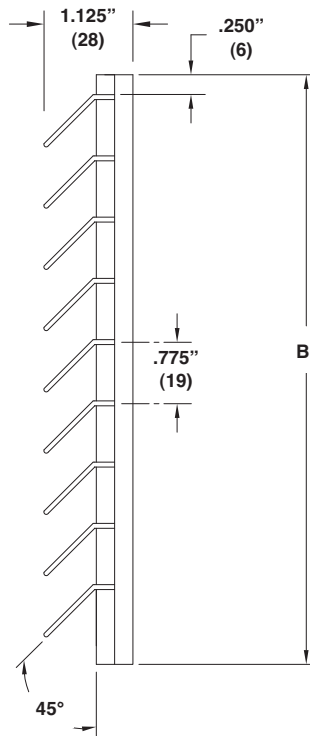
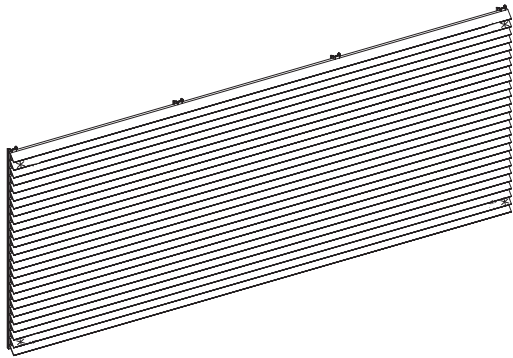
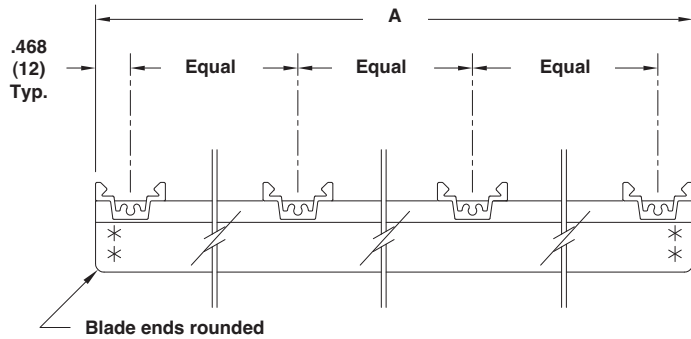

#### STANDARD CONSTRUCTION

- Extruded aluminum; 6063-T5
- 45° architectural decorative louver

#### OPTIONS

- Clear or anodized finish
- Prime coat
- Baked Enamel (Kynar 50%)
- Pearledized 50 or 70
- Kynar 70%
- Frames of choice, see frame submittal sheet

#### VARIATIONS

- A as required, not to exceed 180" (4512)
- B as required, not to exceed 84" (2134)
- Brace bar as required, not to exceed 16" (406)

**Notes:**

1. Face and end views for illustration purposes only
2. Dimensions in inches, parenthesis ( ) indicate millimeters

\*Extension mounting holes as required.

QTY.	ACTUAL SIZE		VARIATIONS
	A	B	
PROJECT ARCH./ENGR. REPRESENTATIVE	 <b>WebREPS</b> 1-800-810-3280		LOCATION CONTRACTOR DATE



1300 ENTERPRISE ROAD GENEVA, ALABAMA 36340-0580 800-239-4621 FAX 1-800-508-1469 www.reliablelouvers.com

### AEL-112

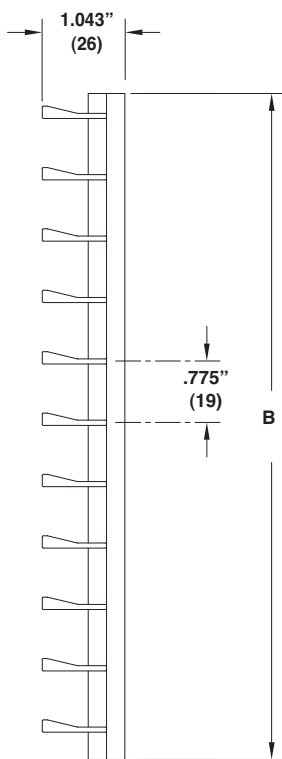
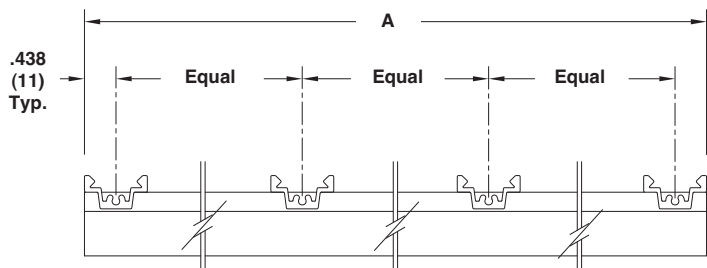

#### STANDARD CONSTRUCTION

- Extruded aluminum; 6063-T5
- Architectural decorative louver w/112 blade

#### OPTIONS

- Clear or anodized finish
- Prime coat
- Baked Enamel (Kynar 50%)
- Pearledized 50 or 70
- Kynar 70%
- Frames of choice. - see frame submittal sheet

#### VARIATIONS

- A as required, not to exceed 180" (4512)
- B as required, not to exceed 84" (2134)
- Brace bar as required, not to exceed 16" (406)

**Notes:**

1. Face and end views for illustration purposes only
2. Dimensions in inches, parenthesis ( ) indicate millimeters

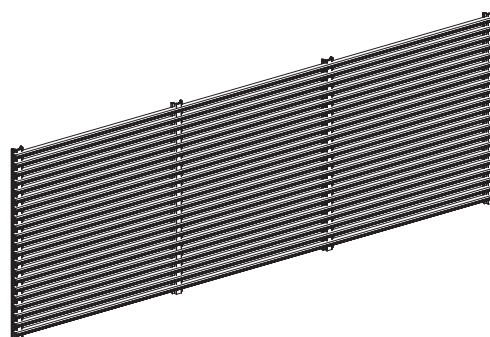

QTY.	ACTUAL SIZE		VARIATIONS
	A	B	
<b>PROJECT ARCH./ENGR. REPRESENTATIVE</b>		<b>WebREPS</b> 1-800-810-3280	<b>LOCATION CONTRACTOR DATE</b>